

2023-2024

SERVING THE
DENTAL INDUSTRY
FOR OVER
30 years!

WE THINK GREEN!



TECHWEST_{INC}

RETAIL PRICE INDEX

TERMS AND CONDITIONS

Prices are subject to change without notice.

No returns are approved without first acquiring a return authorization (R.A.) number. All returns are subject to a 15% restock charge. No returns are authorized after 60 days from the date of shipment.

Payment terms are cash with order or a net payment of 30 days on approved credit. A finance charge of 1 1/2% per month will be charged to an account over 30 days.

A credit line must be established on all open accounts.

Any customer who has allowed their account to become delinquent shall pay Tech West for all legal costs incurred during the necessary collection process.

Any customer allowing their account to become delinquent for extended periods beyond our normal terms will lose their privilege of selling the Tech West product line.

WARRANTY

Warranty service must be obtained through a Tech West, Inc. authorized dealer who carries the Tech West, Inc. product line for which warranty service is requested. It is the retail purchaser's obligation to arrange for delivery, at the retail purchaser's expense, of a product through its authorized dealers for warranty service. It is also the retail purchaser's obligation to comply with the warranty service instructions provided either by Tech West, Inc. or its authorized dealer.

Tech West warrants the original retail purchase within the warranty period of such specified product at Tech West, Inc.'s option to repair or replace components of dental products manufactured by Tech West, Inc. that are defective in material or workmanship under normal use and service. Tech West, Inc.'s obligation under this limited warranty is limited to the repair or replacement of the applicable components.

All part and component returns and replacement equipment under warranty require a Return Materials Authorization (RMA). Warranty returns must be received within 15 days of the RMA issue date. Items returned without an RMA, or included with other products for which an RMA has been issued, will be returned to the customer and no credit will be warranted.

Tech West, Inc. is not liable for indirect or consequential damages or loss of any nature in connection with this equipment. Warranty does not cover dealer labor, or shipping and handling charges inbound to Tech West, Inc. Warranty credit will not be applied to product returns that exhibit damage due to shipping, misuse, careless handling or repairs by Dealer or unauthorized personnel. Credit, or partial credit, will not be issued until products/parts have been received and assessed. Any product is installed or serviced by anyone other than an authorized dealer or service personnel will void all possible warranties.

ALL PARTS HAVE A 90 DAY WARRANTY UNLESS OTHERWISE SPECIFIED.

WARRANTY FOR ALL EXPORT PRODUCT

All Tech West, Inc. products, i.e., vacuums, vacuum systems, and air compressors have a twelve-month or one-year manufacturer's warranty from the date of installation. Our warranty covers only defective parts covered under the warranty period. Labor or other services are excluded.

Warranty does not cover any misuse or improper installation of products. All installation(s) should be installed according to manufacturer installation guidelines. All warranties are evaluated before approval. Improper installations will void all warranties.

All warranty claims export end-users must contact their export distributors.

The terms, conditions and warranties contained herein supersede all previous terms, conditions and warranties, written, expressed or implied, and are in effect January 1, 2005.



TECHWEST INC

Table of Contents

Vacuum Pump Legend	pg. 2
Evacuation System Cleaner	pg. 3
EcoVac Dry Vacuum Pump	pg. 4
Stainless Steel Liquid Ring Vacuum Pump	pg. 5
Compressor Legend	pg. 6
Elite Series Ultra Clean Oilless Compressor	pg. 7
The Elite Series Rocky Oilless Compressor	pg. 8
Remote Control Panels	pg. 9
Water Manifolds	pg. 10
Ultra Clean Air Dryers	pg. 11
Pump Accessories	pg. 11
Accessories	pg. 12

LEGENDS TO HELP YOU DECODE OUR PART NUMBERS

LIQUID RING VACUUM PUMP PART NUMBER LEGEND

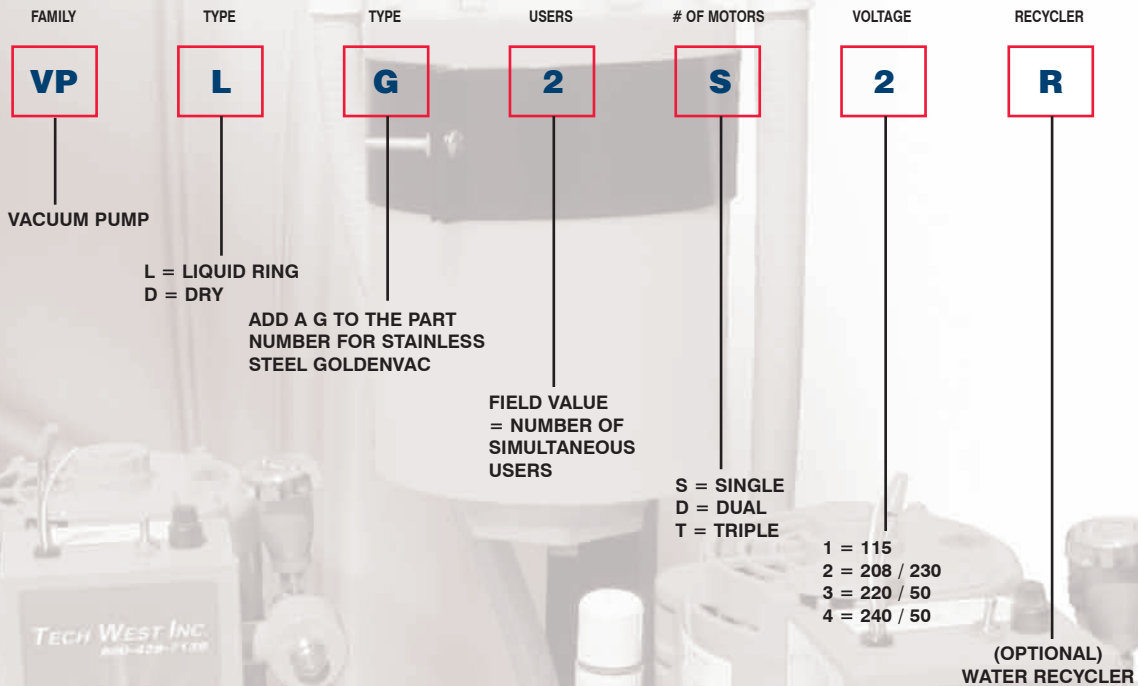

TECH WEST EVACUATION SYSTEM CLEANER



Evacuation System Cleaner

The amount of waste residue (Biofilm/plaque) slogging down your evacuation system depends on the age of your facility, water supply pH, chemical cleaner in use, and how much/often it was used. The Restore Protocol will release the Biofilm/plaque material from the inside of your lines/pipes.

Tech West's Microbial Formula digests organic matter and solids which **GUARANTEES TO MAINTAIN SUCTION PERFORMANCE** and "ELIMINATE" Daily Trap Hand Cleaning. 100% All Natural & Biodegradable. Non-Foaming & SAFE for humans, animals, plants and pipes.

EcoStar-eVac Cleaner comes in two different sizes and the initial amount used to restore the system depends on the age of the system. Detailed instructions are available upon request. It is recommended that EcoStar-eVac Cleaner be used to maintain your system once it is initially cleaned. This will insure cleanliness and long life of the system.

PART#	DESCRIPTION		LIST PRICE
ESC-16	EcoStar-eVac Cleaner	16 oz.	53.00
ESC-32	EcoStar-eVac Cleaner	32 oz.	93.00
ESC-KIT	EcoStar HVE & Si Dispenser	16 oz.	88.00

Note: It is recommended to use 4 oz / chair per month

TECH WEST ECOVAC DRY VACUUM PUMP

Our EcoVac system provides the advantages of proven technology, durable construction, quiet operation and oil-free performance with the latest in water and energy-saving features. This is not only important to you as an environmentally responsible business owner, it also prepares your practice for the upcoming change to metered water usage in many areas of the country. We utilize a Variable Frequency Drive (VFD) to control the vacuum levels. With no suction being used, the motor is running one third the speed and using very little power. Every time a suction hose is being used the motor automatically speeds up to maintain constant suction.

Maintenance free unit with no traps to clean, no oil to check or change. Truly a ZERO maintenance machine.



ECO DRY-VAC SYSTEMS

MODEL NUMBER	MAX USERS	# OF HEADS	TOTAL H.P.	CFM @ 8 HG	TANK GALLONS	VOLTAGE	TOTAL AMPS	BREAKER SIZE	DB(A)	EQUIP. WEIGHT	EQUIP. HEIGHT	EQUIP. WIDTH	EQUIP. DEPTH	SHIPPING WEIGHT	SHIPPING HEIGHT	SHIPPING WIDTH	SHIPPING DEPTH	LIST PRICE
VPD2S2	2-3	1	1	20	14	208/230	10	20	60	139	52	23	20	220	44	42	31	13,258.00
VPD4D2	4-6	2	2	40	14	208/230	10	2X20	62	282	39	40	20	350	44	42	31	23,816.00
VPD5S2	5-7	1	2	45	14	208/230	12	20	62	139	52	23	20	220	44	42	31	14,774.00
VPD10D2	10-14	2	4	90	30	208/230	24	2X20	62	282	39	40	20	325	44	43	31	27,972.00
VPD10D2-14	10-14	2	4	90	30	208/230	24	2X20	62	350	45	43	31	350	45	31	43	27,972.00
VPD15T2	15-21	3	6	110	40	208/230	36	3X20	62	402	60	40	20	455	44	42	31	42,471.00

DVU-S Upgrade 2-3 user single to 5-7 user: 1,966.00 DVU-D Upgrade 4-6 user dual to 10-14 user: 3,933.00
 (VPD10D2 has a 30 gallon tank. Tank weight: 157 lbs. Tank dimensions: 27"W x 28"D x 61"H)

5 YEAR WARRANTY OR 5000 HRS WHICH EVER COMES FIRST

Meets or exceeds NFPA applicable guidelines

FDA
RECOGNIZED

TECH WEST

GOLDENVAC STAINLESS STEEL VACUUM PUMP



Tech West GoldenVac has proved to be the industry leader in design and performance. A vacuum system you can rely on for years to come. All GoldenVac vacuum pumps have an exclusive warranty with 10 years on all stainless steel pump components, 5 years on the motor shaft and all other components have 3 years. The GoldenVac vacuum pumps have an investment cast stainless steel impeller with a radical new design that improves performance by 20% over other pumps. The stainless steel castings provide maximum durability to prevent wear from air abrasion and ceramic particles, or hard water conditions. All motors are thermally protected and are cap-start, cap-run. This will lower the electrical consumption of the pump. Water recyclers and air-water separators are available for all pumps. The GoldenVacs are available in single, dual, or triple configurations. Tech West will provide plumbing and electrical designs upon request.

EXCLUSIVE 10 YEAR WARRANTY

MODEL NUMBER	# OF USERS	VOLTAGE	BREAKER SIZE	H.P.	AIR/WATER SEP	DB(A)	EQUIP. HEIGHT	EQUIP. DEPTH	EQUIP. WIDTH	SHIPPING HEIGHT	SHIPPING DEPTH	SHIPPING WIDTH	LIST PRICE		
VPLG3SS	3	115/230	20	1	NO	70	18	13	13	73	22	18	18	85	3,465.00
VPLG3SSR	3	115/230	20	1	NO	70	18	13	13	75	22	18	18	87	3,740.00
VPLG5SS	5	208/230	20	2	NO	70	18	13	13	89	22	18	18	85	4,588.00
VPLG5SSR	5	208/230	20	2	NO	70	18	13	13	91	22	18	18	87	4,876.00
VPLG6D2	6	208/230	2X20	2X1	YES	72	30	20	28	197	34	21	37	210	7,205.00
VPLG6D2R	6	208/230	2X20	2X1	YES	72	30	20	28	200	34	23	37	212	7,755.00
VPLG10D2	10	208/230	2X20	2X2	YES	72	30	20	28	227	34	23	37	221	9,321.00
VPLG10D2R	10	208/230	2X20	2X2	YES	72	30	20	28	230	34	23	37	223	10,088.00
VPLG15T2	15	208/230	3X20	3X2	YES	74	30	20	41	213	34	23	49	298	14,058.00
VPLG15T2R	15	208/230	3X20	3X2	YES	74	30	20	41	215	34	23	49	300	15,042.00

FDA
RECOGNIZED

Meets or exceeds NFPA applicable guidelines

www.tech-west.com

LEGENDS TO HELP YOU DECODE OUR PART NUMBERS

ULTRA CLEAN AIR COMPRESSOR PART NUMBER LEGEND

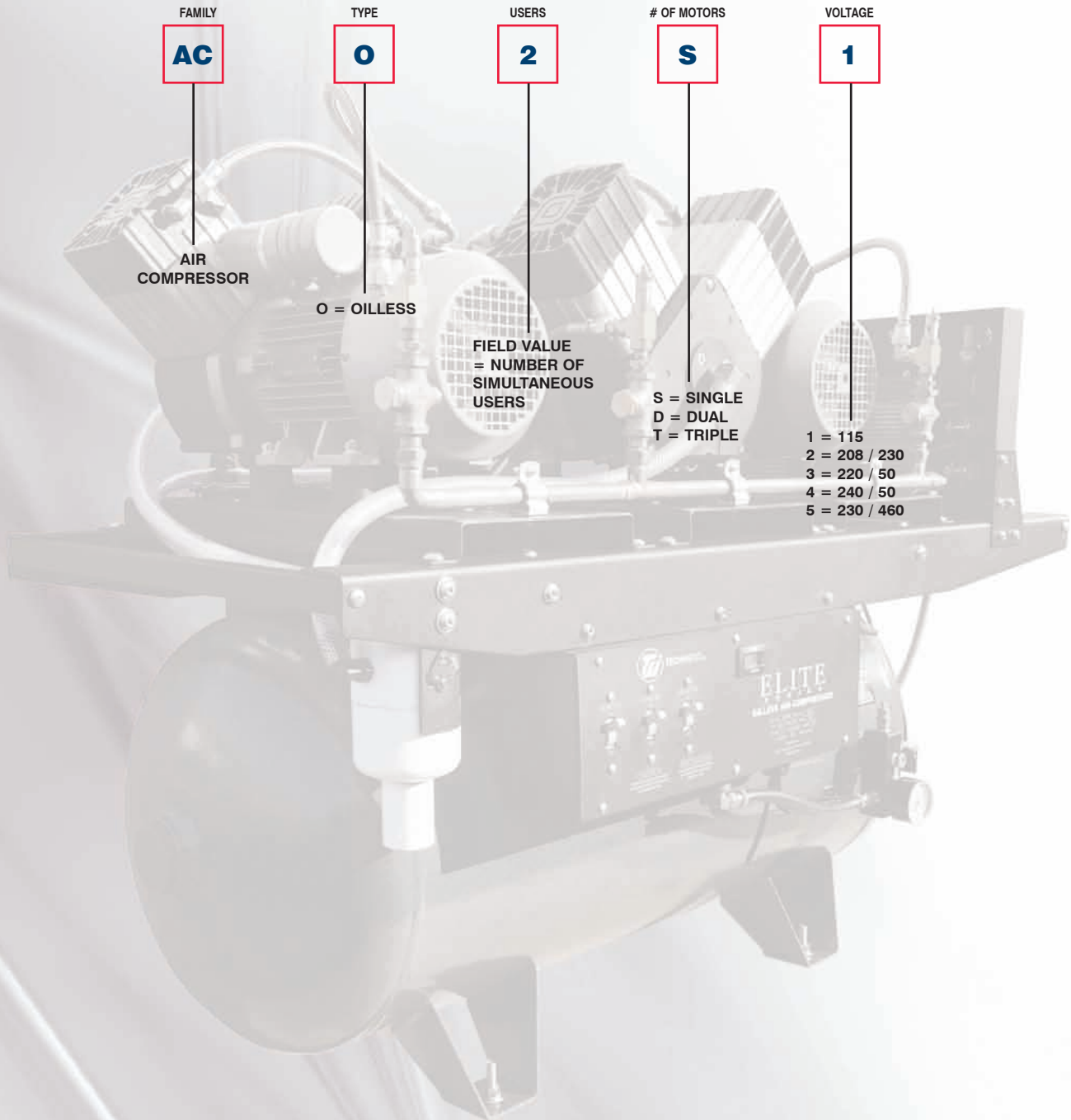

FAMILY

AC

AIR
COMPRESSOR

TYPE

O

O = OILLESS

USERS

2

FIELD VALUE
= NUMBER OF
SIMULTANEOUS
USERS

OF MOTORS

S

S = SINGLE
D = DUAL
T = TRIPLE

VOLTAGE

1

1 = 115
2 = 208 / 230
3 = 220 / 50
4 = 240 / 50
5 = 230 / 460

NEW TECH WEST ELITE SERIES ULTRA CLEAN OILLESS COMPRESSOR

Our Elite Series Oilless Air Compressor system provides the advantages of proven technology, durable construction, quiet operation and oil-free performance with the latest in energy-saving features. This is important to you as an environmentally responsible business owner.

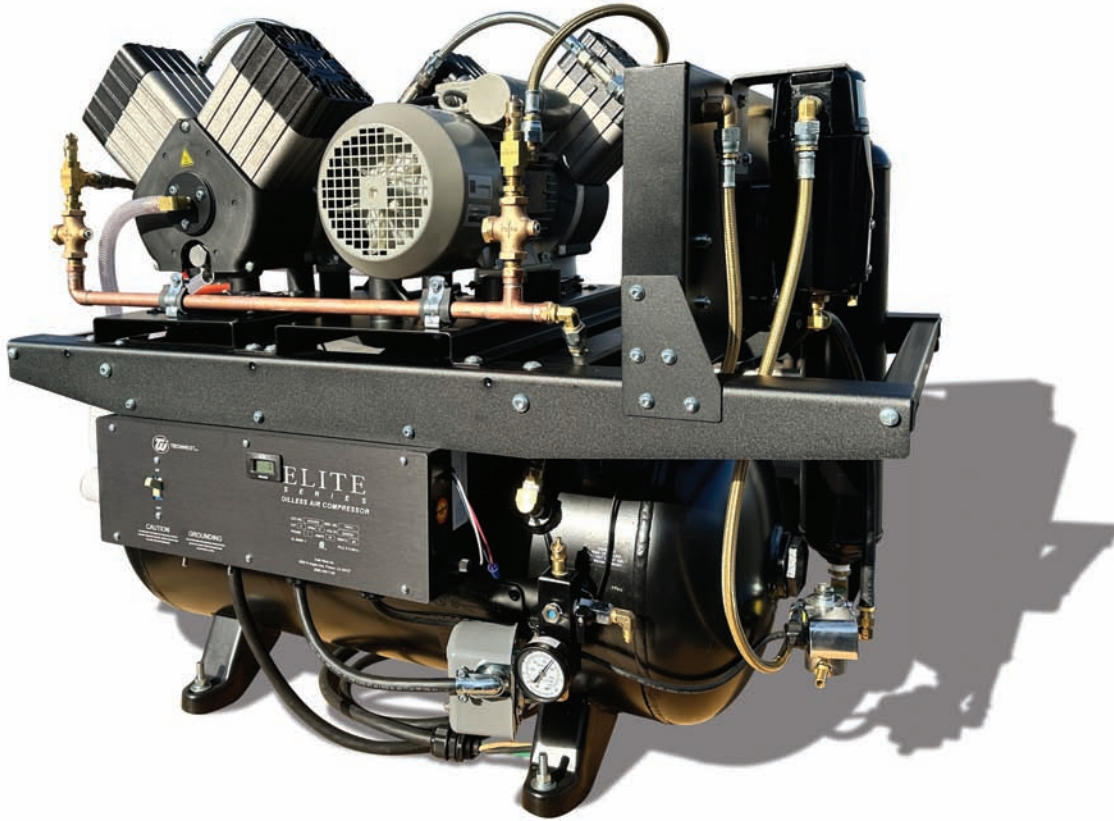

ELITE SERIES OILLESS AIR COMPRESSOR SERIES

MODEL NUMBER	MAX USERS	AIR DRYER	QUIET COVER	# OF HEADS	TOTAL H.P.	CFM	TANK GALLONS	VOLTAGE	TOTAL AMPS	BREAKER SIZE	DB(A)	EQUIP. WEIGHT	EQUIP. HEIGHT	EQUIP. WIDTH	EQUIP. DEPTH	SHIPPING WEIGHT	LIST PRICES
ACO2S2	2-3	YES	NO	1	1.5	5.5	10	208/230	8	20	70	180	30	28	20.5	225	8,494
ESCS-100	QUIET COVER: OPTIONAL FOR THE ACO2S2										68	50	32	28	20.5	50	1,348
ACO4D2	5-7	YES	NO	2	3	11	20	208/230	16	20	72	248	44	42	21	346	13,482
ACO6T2	8-10	YES	NO	3	4.5	16.5	30	208/230	25.5	40	74	320	46	41	31	455	18,538
ESCD-100	QUIET COVER: OPTIONAL FOR THE ACO4D2										68	50	38	29	33	50	1,770

A 5 YEAR or 3500 HR MOTOR WARRANTY. All other components carry a 2 year warranty

Meets or exceeds NFPA applicable guidelines

FDA
RECOGNIZED

NEW TECH WEST ELITE SERIES ROCKY OILLESS AIR COMPRESSOR

The Tech West Rocky Series Oilless Air Compressors provide 100% oil free air to the dental office. With our high performance air drying system, we guarantee the clean dry air you expect. The design of the Tech West Rocky Series Air Compressor provides smooth, quiet, vibration free operation at only 65 dB-a noise level. We offer them in a twin configuration to meet most any need of today's Dental Practice. Tech West will provide full plumbing and electrical design upon request.

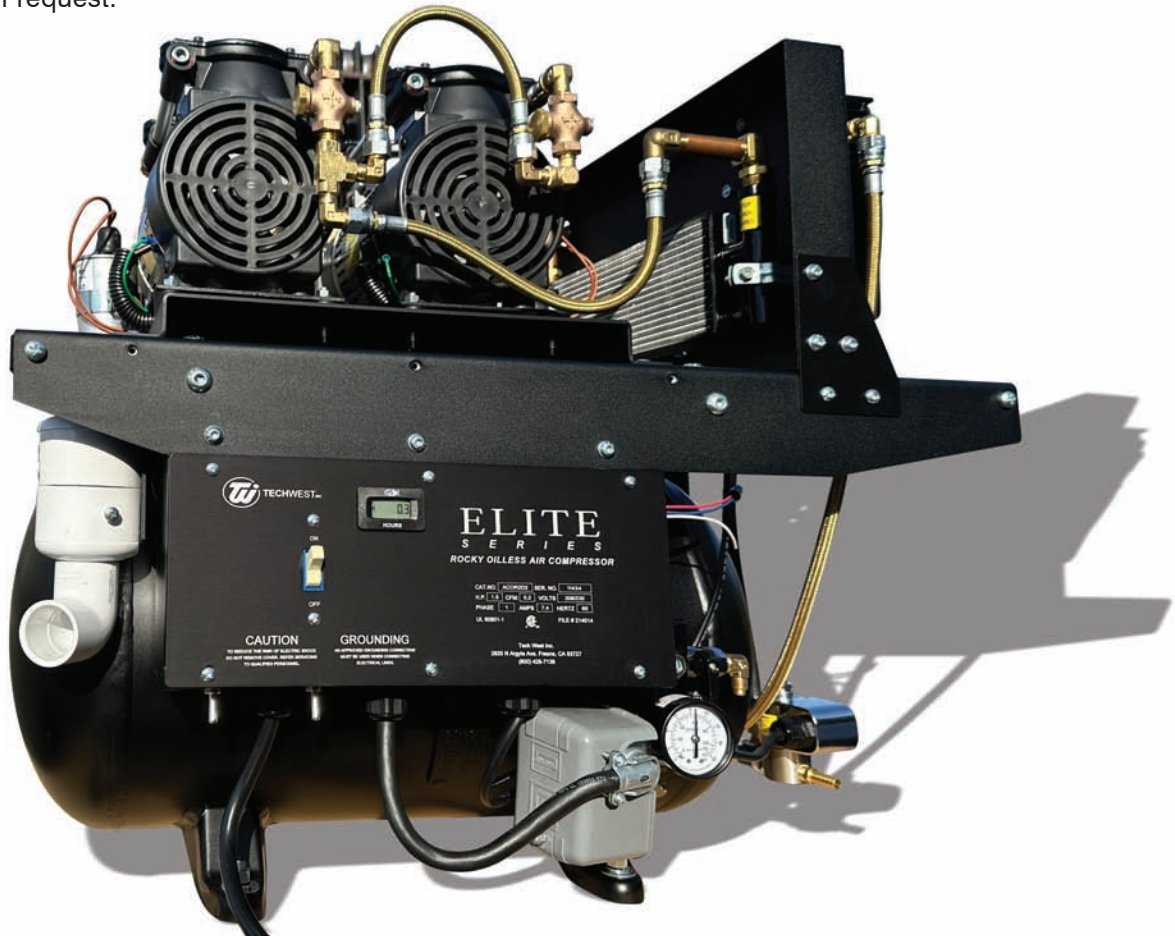

MODEL NUMBER	MAX USERS	AIR DRYER	QUIET COVER	# OF HEADS	TOTAL H.P.	CFM	TANK GALLONS	VOLTAGE	TOTAL AMPS	BREAKER SIZE	DB(A)	EQUIP. WEIGHT	EQUIP. HEIGHT	EQUIP. WIDTH	EQUIP. DEPTH	SHIPPING WEIGHT	SHIPPING HEIGHT	SHIPPING WIDTH	SHIPPING DEPTH	LIST PRICE
ACOR2D1	2-3	YES	NO	2	1.5	5.2	10	115	11	20	68	175	28	28	20.5	220	37	34	28	9,156.00
ACOR2D1Q	2-3	YES	YES	2	1.5	5.2	10	115	11	20	64	210	31	28	20.5	250	37	34	28	10,505.00
ACOR2D2	2-3	YES	NO	2	1.5	5.2	10	208/230	8	20	68	175	28	28	20.5	220	37	34	28	9,156.00
ACOR2D2Q	2-3	YES	YES	2	1.5	5.2	10	208/230	8	20	64	210	31	28	20.5	250	37	34	28	10,505.00

A 5 YEAR 3500 HOUR MOTOR WARRANTY. All other components carry a 2 year warranty.

Meets or exceeds NFPA applicable guidelines

FDA
RECOGNIZED

TECH WEST

REMOTE CONTROL PANELS

Tech West's Remote Control Panels offer a wide variety of different models to suit most any need. All the panels are brushed aluminum with a clear anodized coating that can be mounted onto standard electrical junction boxes. The lighted push buttons are engraved in black to clearly indicate which piece of equipment is on or off.



PART #	DESCRIPTION	HEIGHT	WIDTH	RETAIL PRICE
CP-1V	CONTROL PANEL 1 VAC	4 1/2	4 1/2	222.00
CP-1V1A	CONTROL PANEL 1 VAC 1 AIR	4 1/2	4 1/2	417.00
CP-1V1A1W	CONTROL PANEL 1 VAC 1 AIR 1 H2O	4 1/2	6 1/2	527.00
CP-2A1W	CONTROL PANEL 2 AIR 1 H2O	4 1/2	6 1/2	557.00
CP-2V	CONTROL PANEL 2 VAC	4 1/2	4 1/2	417.00
CP-2V1A	CONTROL PANEL 2 VAC 1 AIR	4 1/2	6 1/2	557.00
CP-2V1A1W	CONTROL PANEL 2 VAC 1 AIR 1 H2O	4 1/2	6 1/2	639.00
CP-3V	CONTROL PANEL 3 VAC	4 1/2	6 1/2	557.00
CP-3V1A	CONTROL PANEL 3 VAC 1 AIR	4 1/2	6 1/2	557.00
CP-3V1A1W	CONTROL PANEL 3 VAC 1 AIR 1 H2O	4 1/2	6 1/2	694.00
CP-4V	CONTROL PANEL 4 VAC	4 1/2	6 1/2	557.00

TECH WEST WATER MANIFOLDS

Tech West's Water Manifolds offer safe after hours protection for today's dental offices. Just push a button on the remote control panel and the water is off. Manifolds are available with or without a filter and with or without a low voltage contactor. The 3/4" unit has a clear filter housing and the 1" has a blue housing.



PART #	DESCRIPTION	HEIGHT	WIDTH	DEPTH	WEIGHT	RETAIL PRICE
WB-100	WTR BYPASS 1" NO FILTER	13	19	4	16	1,683.00
WB-100-RC	WTR BYPASS 1" NO FILTER W/RELAY	13	19	4	22	1,837.00
WB-750	WTR BYPASS 3/4" NO FILTER	10	15 1/2	4	13	993.00
WB-750-RC	WTR BYPASS 3/4" NO FILTER W/RELAY	10	15 1/2	4	18	1,223.00
WBF-100	WTR BYPASS FILTER 1" NO RELAY	24	25	7 1/2	25	1,990.00
WBF-100-RC	WTR BYPASS FILTER 1" W/RELAY	24	25	7 1/2	31	2,298.00
WBF-750	WTR BYPASS FILTER 3/4" NO RELAY	21	19 1/2	6	15	1,301.00
WBF-750-RC	WTR BYPASS FILTER 3/4" W/RELAY	21	19 1/2	6	18	1,531.00

PART #	DESCRIPTION	WEIGHT	RETAIL PRICE
WFE-750	3/4" FILTER ELEMENT PKG OF 4	3	114.00
WFE-100	1" FILTER ELEMENT PKG OF 4	8	228.00

TECH WEST WATER MANIFOLDS HAVE A FULL 2 YEAR WARRANTY

TECH WEST DESICCANT AIR DRYER

Tech West's Ultra Clean Desiccant Air Dryer offers more standard features than any other manufacturer. Our dryer includes coalescing air filter with a .01 micron rating at 99.98% efficiency, moisture indicator and bypass valve, wall mounting bracket, hoses and fittings to hook it up to most any air compressor. These air dryers are easy to install, require minimal maintenance and when service is needed you can replace the desiccant cartridge and coalescing filter in less than ten minutes.

SYSTEM PART #	DESCRIPTION	CAPACITY	HEIGHT	WIDTH	DEPTH	WEIGHT	RETAIL PRICE
UCAD6S-115	SINGLE 115 VOLT AIR DRYER	5 CFM	24	14	12	74	2,505.00
UCAD6S-230	SINGLE 230 VOLT AIR DRYER	5 CFM	24	14	12	75	2,505.00
UCAD12D-230	DUAL 230 VOLT AIR DRYER	10 CFM	24	14	12	75	2,778.00
UCAD18T-230	TRIPLE 230 VOLT AIR DRYER	15 CFM	24	17	12	76	3,057.00



- UCAD6S Dryers come with one hose and check valve for single head compressor.
- UCAD12D Dryers come with two hoses and check valves for dual head compressor
- UCAD18T Dryers come with three hoses and check valves for triple head compressor

TECH WEST PUMP ACCESSORIES



WATER RECYCLER

Tech West's water recycler is a simple yet effective way to save as much as 70% of water consumption. It is factory installed on the pump or can be field installed with ease.

PART#	DESCRIPTION	PRICE
WRK-100	WATER RECYCLER KIT	319.00

P-TRAP ADAPTER

The P-Trap adapter is designed to be used with all Whirlwind Pump models with exhaust separators. The separator waste connection may be hooked to the P-Trap Adapter without worry of splash or vapor contamination. It includes a 1 1/2" ABS slip connection to P-Trap, a stainless steel bridge assembly with 90 degree PVC elbow and adapters for 3/4 drain flex lines.



PART#	PRICE
PTA-100	124.00

STACKING RACK

The stacking rack is designed to reduce the space required to install vacuum and air equipment by about half. The space savings is achieved by placing the stacking rack over your compressor and installing your platform mounted whirlwind pumps on the rack. The stacking rack fits both the dual and triple vacuum systems.



PART #	HEIGHT	WIDTH	DEPTH	WEIGHT	RETAIL PRICE
SR-100	39	43	27	75	974.00

AIR WATER SEPARATOR WITH VAPOR STOP

Air-water separators are available in single, dual, and triple models. They are designed to separate the liquids entrained in the exhaust. A vapor-stop fitting allows the liquids to create a gas and vapor trap, thereby eliminating odors and contaminants from entering the equipment location. All models include vapor-stop, hoses, fittings, P-trap adapter and a mounting bracket.



PART #	DESCRIPTION	HEIGHT	WIDTH	DEPTH	WEIGHT	RETAIL PRICE
ES-1	SINGLE	16	16	9	18	487.00
ES-2	DUAL	16	16	9	18	558.00
ES-3	TRIPLE	16	16	11	18	629.00

TECH WEST ACCESSORIES

COMPRESSOR OIL

Our compressor oil is specially formulated for our oil lubricated compressors. It is a very high grade of synthetic lubricant with an additive to help reduce piston friction and wear.



PART# CO-100 PRICE 63.00
(Case of 4)

RELAY CONTROL 24V/115-230V

For 24V remote switching of compressors, water manifolds, and other electrical devices. Relay provides 40 amp. resistive load capability, 30VA and 24 VAC transformer. Fused on 24V side.



PART#	DESCRIPTION	PRICE
RC-115	115V RELAY CONTROL	314.00
RC-230	230V RELAY CONTROL	314.00

BOOST TRANSFORMER

When line voltage at an installation site is below 208 volts for a Whirlwind pump or Ultra Clean compressor, it is recommended that a boost transformer be installed. They are pre-wired for quick installation. Select your booster based on total horsepower of your Whirlwind pump or Ultra Clean compressor. All dual and triple model Whirlwinds should use individual boosters for each vacuum pump or separate circuits.



PART #	DESCRIPTION	WEIGHT	RETAIL PRICE
BT-1-115	1 HP 115 V.	18	694.00
BT-1-230	1 HP 230 V.	18	694.00
BT-2-230	2 HP 230 V.	18	834.00
BT-3-230	3 HP 230 V.	23	974.00





TECHWEST INC

Manufacturers of Dental Vacuum
and Air Systems

2657 N. Argyle Ave. • Fresno, CA 93727
(559) 291-1650 • (800) 428-7139
FAX (559) 348-9677
www.tech-west.com

Revised 2/23